

## HR-1200

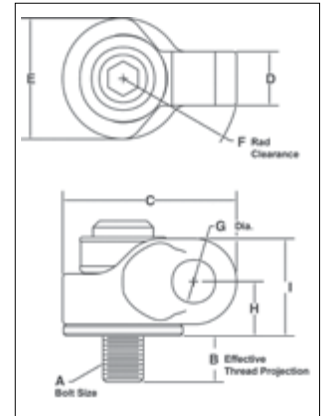

- Body components are alloy steel - Quenched & Tempered.
- Rated at 100% of Working Load Limit for angles up to 90 degrees.
- Each product is stamped with a Product Identification Code (PIC) for material traceability, along with a Working Load Limit, and the name Crosby or "CG."
- Hoist ring body is furnished with a yellow chromate finish for improved corrosion resistance.
- Utilize standard Crosby Red Pin® Shackles to connect to wire rope or synthetic slings (sold separately).
- Multiple bolt lengths available to meet specific application requirements.
- Individually Proof Tested to 2-1/2 times Working Load Limit.



## HR-1200 UNC Side Pull Hoist Rings

Weight Each (lb)	Working Load Limit (lb)	Stock No.	Hoist Ring Bolt Torque (ft-lb)	Bolt Size A	Eff. Thread Proj. (in) B	Dimensions (in)							Recommended Shackles			Replacement Bolt Kit Stock No.
						C	D	E	F	Dia. G	H	I	Shackles 209, 210, 213, 215, 2130, 2150		Web Shackles S-281	
													Nominal Size (in)	Web Size (in)		
.35	650	1067700	7	5/16-18x1.50	.59	1.93	.72	1.00	1.56	.80	.85	1.43	1/2, 5/8	2	1015502	
.36	800	1067704	12	3/8-16x1.50	.59	1.93	.72	1.00	1.56	.80	.85	1.43	1/2, 5/8	2	1015533	
1.4	2000	1067708	28	1/2-13x2.00	.71	2.97	.97	2.00	2.13	.93	1.07	1.79	5/8, 3/4	2, 1-1/2	1015566	
1.4	2000	1067712	28	1/2-13x2.50	1.21	2.97	.97	2.00	2.13	.93	1.07	1.79	5/8, 3/4	2, 1-1/2	1015575	
1.5	3000	1067716	60	5/8-11x2.00	.71	2.97	.97	2.00	2.13	.93	1.07	1.79	5/8, 3/4	2, 1-1/2	1015599	
1.5	3000	1067720	60	5/8-11x2.75	1.46	2.97	.97	2.00	2.13	.93	1.07	1.79	5/8, 3/4	2, 1-1/2	1015610	
4.5	5000	1067724	100	3/4-10x2.75	.90	4.32	1.34	3.00	3.00	1.07	1.35	2.42	7/8	2	1015646	
4.6	5000	1067728	100	3/4-10x3.50	1.65	4.32	1.34	3.00	3.00	1.07	1.35	2.42	7/8	2	1015676	
4.6	6500	1067732	160	7/8-9x2.75	.90	4.32	1.34	3.00	3.00	1.07	1.35	2.42	7/8	2	1015698	
4.8	6500	1067736	160	7/8-9x3.50	1.65	4.32	1.34	3.00	3.00	1.07	1.35	2.42	7/8	2	1015707	
4.8	8000	1067740	230	1-8x3.00	1.15	4.32	1.34	3.00	3.00	1.07	1.35	2.42	7/8	2	1015731	
5.0	8000	1067744	230	1-8x4.00	2.15	4.32	1.34	3.00	3.00	1.07	1.35	2.42	7/8	2	1015740	
10.2	14000	1067748	470	1-1/4-7x4.5	2.22	5.59	1.57	3.75	3.91	1.47	1.92	3.42	1, 1-1/8, 1-1/4	3	1015762	
23.5	17200	1067756	800	1-1/2-6x6.5	2.98	7.31	2.06	4.75	5.19	2.11	2.41	4.29	1-3/8, 1-1/2, 1-3/4	-	-	
25.3	29000	1067764	1100	2-4.5x6.5	2.98	7.31	2.06	4.75	5.19	2.11	2.41	4.29	1-3/8, 1-1/2, 1-3/4	-	-	

5:1 Design Factor.

11

## HR-1200M Metric Side Pull Hoist Rings

Weight Each (kg)	Working Load Limit (kg)	Stock No.	Hoist Ring Bolt Torque (Nm)	Bolt Size A	Eff. Thread Proj. (mm) B	Dimensions (mm)							Recommended Shackles			Replacement Bolt Kit Stock No.
						C	D	E	F	G	H	I	Shackles 209, 210, 213, 215, 2130, 2150		Web Shackles S-281	
													Nominal Size (in)	Web Size (in)		
.18	300	1067803	10	M8x1.25x40	16.9	49.0	18.3	25.4	39.6	20.3	21.6	36.3	1/2, 5/8	2	1015875	
.18	400	1067807	16	M10x1.50x40	16.9	49.0	18.3	25.4	39.6	20.3	21.6	36.3	1/2, 5/8	2	1015884	
.63	1000	1067811	38	M12x1.75x50	17.2	75.4	24.6	50.8	54.1	23.6	27.2	45.5	5/8, 3/4	2, 1-1/2	1015897	
.68	1400	1067815	81	M16x2.0x60	27.2	75.4	24.6	50.8	54.1	23.6	27.2	45.5	5/8, 3/4	2, 1-1/2	1015906	
2.0	2250	1067823	136	M20x2.5x75	28.1	110	34.0	76.2	76.2	27.2	34.4	61.5	7/8	2	1015930	
2.2	3500	1067827	312	M24x3.0x80	33.1	110	34.0	76.2	76.2	27.2	34.4	61.5	7/8	2	1015941	
4.5	6250	1067831	637	M30x3.5x120	65.1	142	39.9	95.3	99.3	37.3	48.8	86.9	1, 1-1/8, 1-1/4	3	1015952	
10.4	7750	1067835	1005	M36x4.0x150	60.6	186	52.3	121	132	53.6	61.2	109	1-3/8, 1-1/2, 1-3/4	-	-	
10.7	10000	1067839	1005	M42x4.5x160	70.6	186	52.3	121	132	53.6	61.2	109	1-3/8, 1-1/2, 1-3/4	-	-	
11.0	13000	1067843	1350	M48x5.0x160	70.6	186	52.3	121	132	53.6	61.2	109	1-3/8, 1-1/2, 1-3/4	-	-	

5:1 Design Factor.



APPLICATION AND WARNING INFORMATION SECTION 17